

DIGITAL CAMERA
ORCA[®]-Flash4.0LT

Be brilliant.



HAMAMATSU
PHOTON IS OUR BUSINESS

Be brilliant.

The ORCA-Flash4.0 LT makes it easy to be brilliant. With 2x the speed, 3x the field of view and up to 5x the signal to noise over even the best interline CCD cameras, the ORCA-Flash4.0 LT brings high end performance to every imaging project. From brightfield to fluorescence, from live cell to fixed tissue, from routine to ground-breaking, the ORCA-Flash4.0 LT is designed to be the new workhorse digital camera. The ORCA-Flash4.0 LT shines with the most experienced implementation of Gen II sCMOS technology, and realizes the long-awaited promise of luxury CCD performance at affordable CMOS price.



Applications where ORCA-Flash4.0 LT shines

Multi-dimensional imaging

Collect large data sets from x, y or z with multiple wavelengths more efficiently. The combined features of large field of view, low light performance and speed means less time at the scope and more time finding the answers.

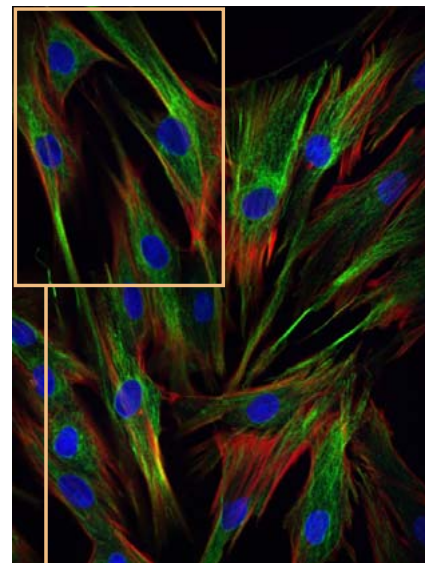

◀ 12 images (4 positions x 3 wavelengths) merged and tiled to create one composite image.

Sample: Porcine Aortic Smooth Muscle Cells
Fluorescent Probe: nucleus (Hoechst 33342), tubulin (Alexa Fluor 488), F-actin (Alexa Fluor 546)
Objective Lens: 60x oil
Confocal Scanner: Yokogawa CSU-X1
Light source: Light Engine Spectra X

Courtesy of Kazuaki Nagayama, Ph.D., Associate Professor, Nagoya Institute of Technology

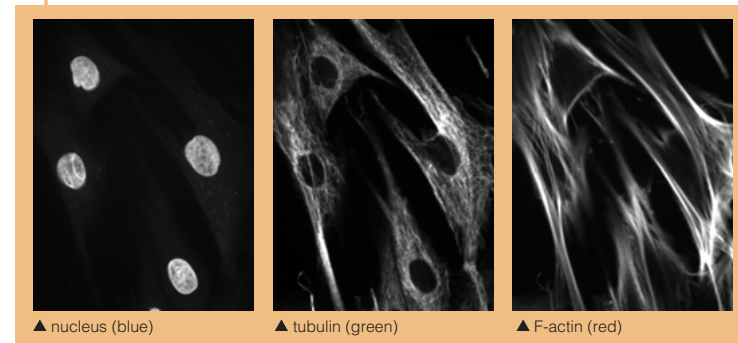

▲ nucleus (blue) ▲ tubulin (green) ▲ F-actin (red)

3D imaging

Multi-wavelength Z-series with resulting 3D reconstruction.

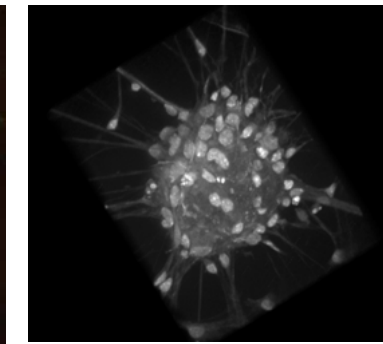
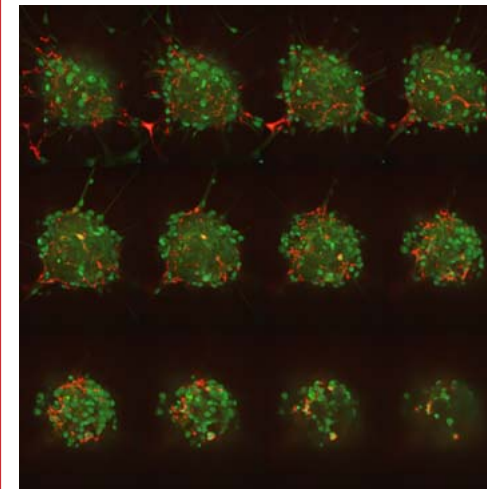

◀ 3D image (Cy2)

Sample: Mouse Neural Stem Cells
Fluorescent Probe: DAPI, Cy2, Cy3
Objective Lens: 60x oil
Z step: 0.6 μm
Confocal Scanner: Yokogawa CSU-X1
Light source: Light Engine Spectra X

Ratiometric Ca²⁺ imaging

Spontaneous calcium oscillations in Ins-1 cells acquired through simultaneous imaging of CFP/YFP. The large field of view of the ORCA-Flash4.0 LT makes it possible to capture meaningful data even when using split image optics.

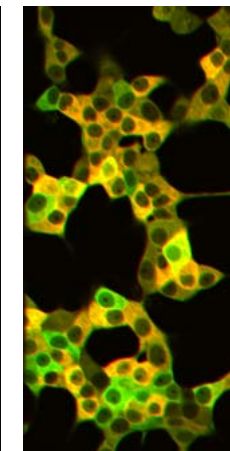
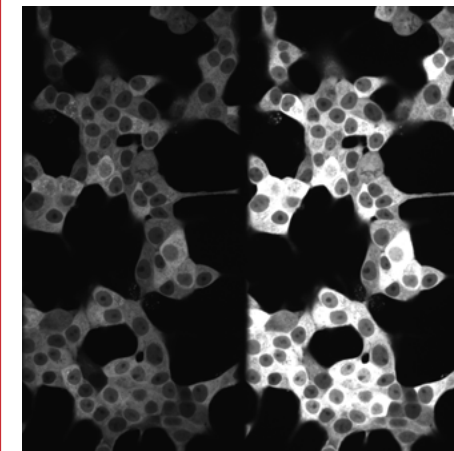

Sample: Ins-1 Cells
Fluorescent Probe: Yellow Cameleon3.60
Objective Lens: 60x water
Confocal Scanner: Yokogawa CSU-W1 SplitView
Light source: Laser 440 nm

▲ Left: CFP, Right: YFP

▲ Ratio image

Performance beyond interline CCD

Excellent image quality

The combination of high quantum efficiency and low noise allows the ORCA-Flash4.0 LT to produce images that are both visually pleasing and quantitatively relevant. The ORCA-Flash4.0 LT exceeds the SNR performance of Gen I sCMOS at all input photon levels and that of interline CCDs at less than 5000 photons per pixel. This means reduced exposure times that maintain strong SNRs across a broad range of sample intensities while at the same time providing wide field of view and better temporal resolution as compared to CCDs.

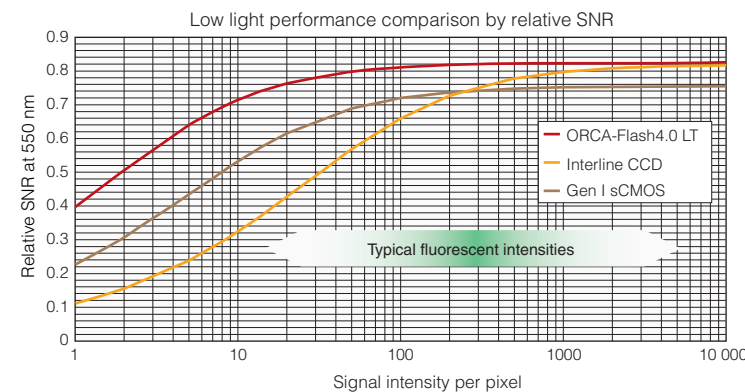
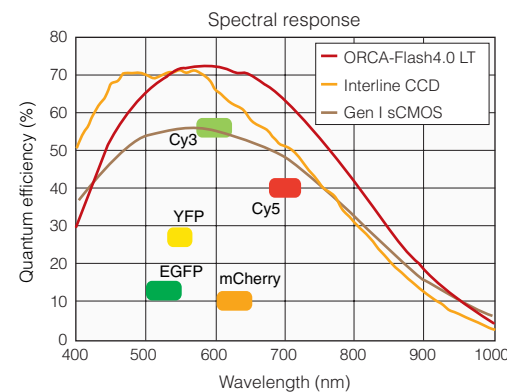

Large field of view

The ORCA-Flash4.0 LT provides 3x larger field of view compared to commonly used interline CCDs (e.g., ICX285) and is ideally suited to utilize the entire field of view of research microscopes.

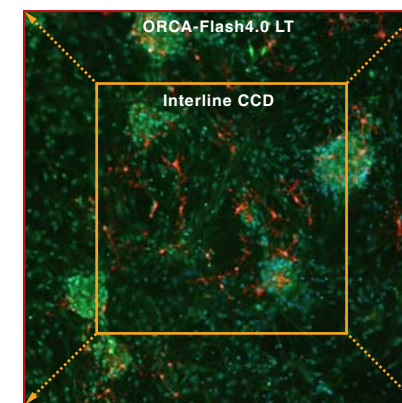

Fast speed

The ORCA-Flash4.0 LT provides 2x frame rate at full resolution as compared to interline CCDs enabling high-speed image acquisition with wide field of view.

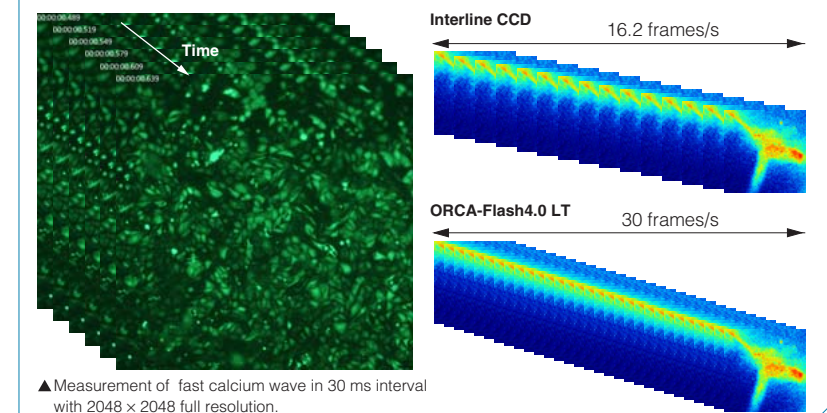

▲ Measurement of fast calcium wave in 30 ms interval with 2048 x 2048 full resolution.

Specifications

Product number	C11440-42U (ORCA-Flash4.0 LT)
Imaging device	Scientific CMOS sensor FL-400
Effective number of pixels	2048(H) × 2048(V)
Cell size	6.5 μm × 6.5 μm
Effective area	13.312 mm × 13.312 mm
Full well capacity (typ.)	30 000 electrons
Readout noise (typ.)	0.9 electrons (median), 1.5 electrons (rms)
Readout noise (Rapid rolling mode) (typ.)	1.3 electrons (median), 1.9 electrons (rms)
Dynamic range (typ.) ¹	33 000:1
Quantum efficiency	Over 70 % at 600 nm
Cooling temperature	10 °C (Ambient 25 °C)
Dark current (typ.)	0.6 electrons/pixel/s
PRNU (Column fixed pattern noise ²)	≤ 0.1 %
MTF (Theoretical)	76.9 lp/mm
Frame rate ³	
Full resolution	30 frames/s
2048 × 1024 ⁴	60 frames/s
2048 × 8 ⁴	7696 frames/s
512 × 8 ⁴	25 000 frames/s (Rapid rolling mode only)
AD conversion ⁵	16 bit
Readout mode	Digital binning 2 × 2/4 × 4 Sub-array readout mode
Exposure time ⁶	
Internal trigger mode	3 ms to 10 s
Internal trigger mode with sub-array readout	130 μs to 10 s
External trigger mode	3 ms to 10 s
Exposure time (Rapid rolling mode) ⁶	
Internal trigger mode	1 ms to 10 s
Internal trigger mode with sub-array readout	40 μs to 10 s
External trigger mode	1 ms to 10 s
Interface	USB 3.0
Lens mount	C-mount / F-mount ⁷
Power requirement	AC 100 V to AC 240 V, 50 Hz/60 Hz
Power consumption	Approx. 75 VA
Storage ambient temperature	-10 °C to 50 °C
Operating ambient temperature	0 °C to 40 °C
Operating ambient humidity	70 % or less (non-condensation)
Trigger in	
External trigger mode	Edge, Level, Synchronous readout, Start trigger Global reset edge, Global reset level
External trigger signal routing	SMA
External trigger delay function	0 to 10 s (10 μs steps)
Trigger out	
External signal output	3 programmable timing outputs Global exposure timing output Trigger ready output Multi-channel sync output
External signal output routing	SMA
Software	
Software interface	PC-based acquisition package included DCAM-SDK, commercially available software

*1 Full well capacity/Readout noise median

*2 Measured at 70 % of full well capacity

*3 Optimal running condition. For more information refer to http://www.hamamatsu.com/resources/pdf/sys/SCAS0095E01_Global.pdf

*4 Measured center of image.

*5 The true 16 bit image data is achieved through seamless merging of the output from two 11 bit A/D converters.

*6 Minimum exposure time in internal trigger mode varies depending on sub-array size and position.

*7 Product number of F-mount camera is C11440-42U01

ORCA is registered trademark of Hamamatsu Photonics K.K. (France, Germany, Japan, U.K., U.S.A.)

HCIMAGE is registered trademark of PHOTONICS MANAGEMENT CORP. (Australia, China, EU, Japan, Norway, Singapore, Switzerland, U.S.A.)

Product and software package names noted in this documentation are trademarks or registered trademarks of their respective manufacturers.

● Subject to local technical requirements and regulations, availability of products included in this promotional material may vary. Please consult your local sales representative.

● Information furnished by HAMAMATSU is believed to be reliable. However, no responsibility is assumed for possible inaccuracies or omissions.

Specifications and external appearance are subject to change without notice.

© 2014 Hamamatsu Photonics K.K.

HAMAMATSU PHOTONICS K.K. www.hamamatsu.com

HAMAMATSU PHOTONICS K.K., Systems Division

812 Joko-cho, Higashi-ku, Hamamatsu City, 431-3196, Japan, Telephone: (81)53-431-0124, Fax: (81)53-435-1574, E-mail: export@sys.hpk.co.jp

U.S.A.: Hamamatsu Corporation: 360 Foothill Road, Bridgewater, NJ 08807, U.S.A., Telephone: (1)908-231-0960, Fax: (1)908-231-1218 E-mail: usa@hamamatsu.com

Germany: Hamamatsu Photonics Deutschland GmbH: Arzbergerstr. 10, D-82211 Herrsching am Ammersee, Germany, Telephone: (49)8152-375-0, Fax: (49)8152-265-8 E-mail: info@hamamatsu.de

France: Hamamatsu Photonics France S.A.R.L.: 19, Rue du Saule Trapu, Parc du Moulin de Massy, 91882 Massy Cedex, France, Telephone: (33)1 69 53 71 00, Fax: (33)1 69 53 71 10 E-mail: infos@hamamatsu.fr

United Kingdom: Hamamatsu Photonics UK Limited: 2 Howard Court, 10 Tewin Road, Welwyn Garden City, Hertfordshire AL7 1BW, UK, Telephone: (44)1707-294888, Fax: (44)1707-325777 E-mail: info@hamamatsu.co.uk

North Europe: Hamamatsu Photonics Norden AB: Torshamnsgatan 35 16440 Kista, Sweden, Telephone: (46)8-509-031-00, Fax: (46)8-509-031-01 E-mail: info@hamamatsu.se

Italy: Hamamatsu Photonics Italia S.r.l.: Strada della Moia, 1 int. 6 20020 Arese (Milano), Italy, Telephone: (39)02-93581733, Fax: (39)02-93581741 E-mail: info@hamamatsu.it

China: Hamamatsu Photonics (China) Co., Ltd.: B1201 Jiaming Center, No.27 Dongsanhuan Bellu, Chaoyang District, Beijing 100020, China, Telephone: (86)10-6586-6006, Fax: (86)10-6586-2866 E-mail: hpc@hamamatsu.com.cn

Dimensional outlines

Camera (Approx. 1.1 kg)

Unit: mm

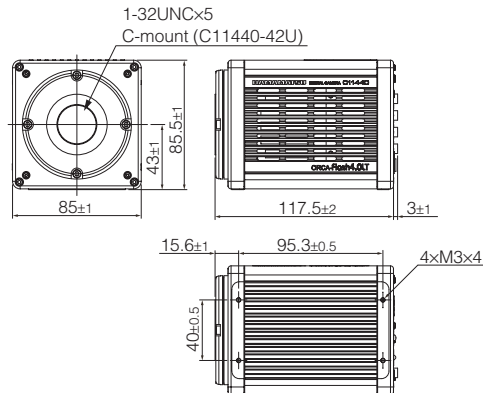

Configuration example

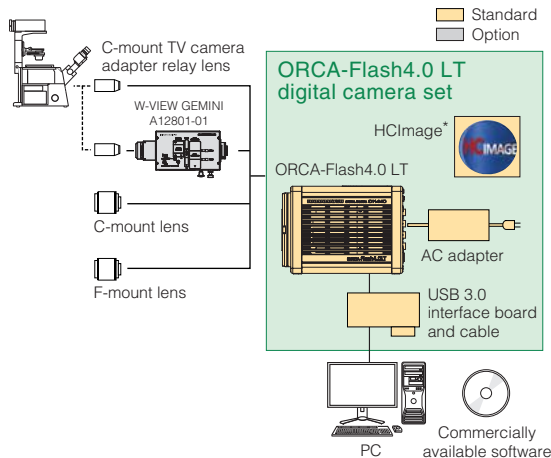

*HCImage software provides standard image measurements functions. Upgrades to more feature-rich versions are available.

Please contact your local Hamamatsu representative or distributor regarding actual configuration.

